

## HARMONIC ANALYSIS LECTURE 2

NOAH GORRELL

ABSTRACT. This lecture is largely divided into two parts. In the first part, we explore some heuristics about how the Fourier transform acts on characteristic functions of rectangles. In the second part, we introduce Sobolev spaces on  $\mathbb{R}^n$  and see some results about the Littlewood-Paley decomposition.

### USEFUL HEURISTICS (LIES) ABOUT THE FOURIER TRANSFORM

**Intervals in  $\mathbb{R}$ .** Given a subset  $E \subset \mathbb{R}^n$ , we denote by  $\mathbf{1}_E$  the characteristic function of  $E$  on  $\mathbb{R}^n$ .

**Lie 1.** Let  $I = [-\frac{1}{2}, \frac{1}{2}]$ . We have  $\widehat{\mathbf{1}}_I = \mathbf{1}_I$ .

*“Proof”.* We compute the Fourier transform using the fundamental theorem of calculus. For any  $\xi \in \mathbb{R}$ ,

$$\widehat{\mathbf{1}}_I(\xi) = \int_{-1/2}^{1/2} e^{-2\pi i x \xi} dx = \frac{e^{-\pi i \xi} - e^{\pi i \xi}}{-2\pi i \xi} = \frac{\sin(\pi \xi)}{\pi \xi}.$$

Therefore, when  $\xi \sim 0$ , we have  $\widehat{\mathbf{1}}_I(\xi) \sim 1$ . Moreover, as  $|\xi| \rightarrow \infty$ , we have  $\widehat{\mathbf{1}}_I(\xi) = O(|\xi|^{-1})$ . Therefore, we approximate  $\widehat{\mathbf{1}}_I \sim \mathbf{1}_I$ .  $\square$

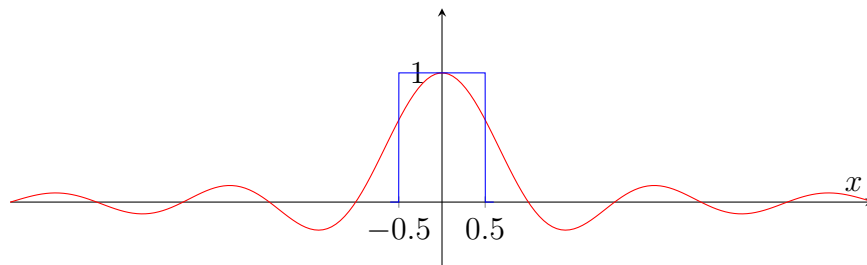

FIGURE 1. A comparison of  $\widehat{\mathbf{1}}_I(x)$  (red) with  $\mathbf{1}_I(x)$  (blue)

For the remainder of this section, we will accept this lie as bible and see what we can deduce.

First, recall the following facts about the Fourier transform, which can be checked directly using a change of variables.

---

*Date:* September 29, 2025.

**Lemma 1.** Let  $f \in L^1(\mathbb{R}^n)$ . Fixing  $a \in \mathbb{R}^n$ ,  $\lambda \in \mathbb{R}$ , and an orthogonal matrix  $R \in O(n)$ , define  $f_a(x) = f(x - a)$ ,  $f_\lambda(x) = f(\lambda^{-1}x)$ , and  $f_R(x) = f(Rx)$ ,  $x \in \mathbb{R}^n$ . Then for all  $\xi \in \mathbb{R}^n$ ,

- (i)  $\widehat{f}_a(\xi) = e^{-2\pi i a \cdot \xi} \widehat{f}(\xi)$
- (ii)  $\widehat{f}_\lambda(\xi) = |\lambda|^n \widehat{f}(\lambda \xi)$
- (iii)  $\widehat{f}_R(\xi) = \widehat{f}(R\xi)$

With these facts in hand, we can generalise the “result” in Lie 1 to arbitrary intervals in  $\mathbb{R}$ .

**Proposition 1.** Given an interval  $I \subset \mathbb{R}$ , let  $I^* = [-\frac{1}{2|I|}, \frac{1}{2|I|}]$ . Letting  $a$  denote the midpoint of the interval  $I$ ,  $\widehat{\mathbf{1}}_I(\xi) = e^{-2\pi i a \xi} |I| \mathbf{1}_{I^*}(\xi)$ .

*Proof.* We assume without loss of generality that  $I$  is closed. First, assume  $a = 0$ , so  $I = [-\frac{r}{2}, \frac{r}{2}]$  for some  $r > 0$ . Then  $\mathbf{1}_I(x) = \mathbf{1}_{[-\frac{1}{2}, \frac{1}{2}]}(\frac{x}{r})$ . By Lemma 1(ii), we get  $\widehat{\mathbf{1}}_I(\xi) = r \widehat{\mathbf{1}}_{[-\frac{1}{2}, \frac{1}{2}]}(r\xi)$ . Using Lie 1, we conclude that  $\widehat{\mathbf{1}}_I(\xi) = r \mathbf{1}_{[-\frac{1}{2}, \frac{1}{2}]}(r\xi) = r \mathbf{1}_{[-\frac{1}{2r}, \frac{1}{2r}]}(\xi)$ . Since  $r = |I|$ , this has the desired form.

Now, for general  $I$ , we write  $I = [a - \frac{r}{2}, a + \frac{r}{2}]$ . Then we have  $\mathbf{1}_I(x) = \mathbf{1}_{[-\frac{r}{2}, \frac{r}{2}]}(x - a)$ , and therefore  $\widehat{\mathbf{1}}_I(\xi) = e^{-2\pi i a \xi} \widehat{\mathbf{1}}_{[-\frac{r}{2}, \frac{r}{2}]}(\xi)$ . By our observation above, it follows that  $\widehat{\mathbf{1}}_I(\xi) = e^{-2\pi i a \xi} r \mathbf{1}_{[-\frac{1}{2r}, \frac{1}{2r}]}(\xi)$ . Since  $r = |I|$ , this is exactly what we hoped for.  $\square$

Taking absolute values, we have  $|\widehat{\mathbf{1}}_I| = |I| \widehat{\mathbf{1}}_{I^*}$ . An example of this equality is depicted in Figure 2.

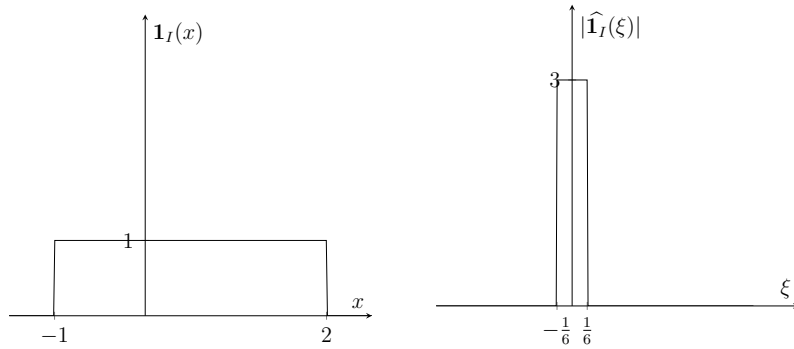

FIGURE 2. Proposition 1 when  $I = [-1, 2]$

We make two observations about what we have shown. First, when  $I$  is a large interval (that is, when the function  $\mathbf{1}_I$  is “spread-out”), the interval  $I^*$  is small (that is, the function  $\widehat{\mathbf{1}}_I$  is concentrated near 0).

Second, one can see that  $\|\mathbf{1}_I\|_{L^1} = |I| = \|\widehat{\mathbf{1}}_I\|_{L^\infty}$  and  $\|\mathbf{1}_I\|_{L^2} = |I|^{1/2} = \|\widehat{\mathbf{1}}_I\|_{L^2}$ . These two observations reflect the usual behaviour of the Fourier transform, indicating that the approximation in Lie 1 is a good heuristic for how the Fourier transform works.

We saw in the above “proof” that  $\widehat{\mathbf{1}}_I$  is just an oscillation with frequency  $a$ , cut off in the dual interval  $I^*$ . What if we were to replace  $a$  with a different point in  $I$ ? How well can we approximate  $\widehat{\mathbf{1}}_I$  by an oscillation with a different frequency?

For any  $b \in I$  and  $\xi \in I^*$ , we have  $|b - a| \leq \frac{|I|}{2}$  and  $|\xi| \leq \frac{1}{2|I|}$ . Hence,  $|b\xi - a\xi| \leq \frac{1}{4}$ , and so the oscillations  $e^{-2\pi ia\xi}$  and  $e^{-2\pi ib\xi}$  cannot fall too far out of phase for  $\xi \in I^*$ . Hence, we approximate  $\widehat{\mathbf{1}}_I(\xi) \sim e^{-2\pi ib\xi} |I| \mathbf{1}_{I^*}$ .

**Generalisation to  $\mathbb{R}^n$ .** The interval  $I^*$  in Proposition 1 is called the **dual interval** to  $I$ . We can generalise this notion to higher dimensions and thereby generalise the result in Proposition 1.

**Definition 1.** Let  $\Theta \subset \mathbb{R}^n$  be a rectangle. The **dual rectangle**  $\Theta^* \subset \mathbb{R}^n$  is the rectangle centred at 0 with faces parallel to the faces of  $\Theta$ , but where the sidelength of each edge is the reciprocal of the length of the corresponding edge in  $\Theta$ . Such a construction is depicted in Figure 3.

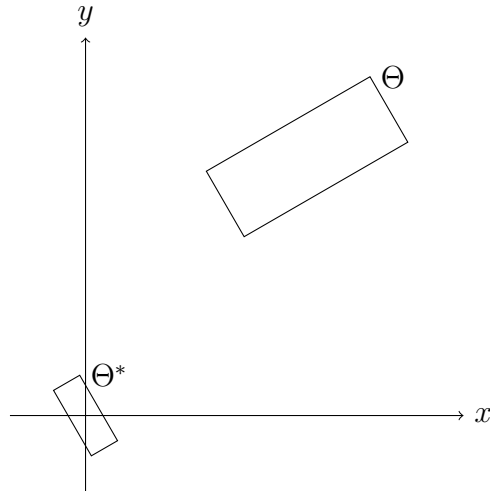

FIGURE 3. A rectangle  $\Theta$  (left) and its dual  $\Theta^*$  (right)

We can compute  $\Theta^*$  more precisely as follows. If the sides of  $\Theta$  are parallel to the coordinate axes, that is  $\Theta = \prod_{j=1}^n [a_j, b_j]$  for some

$a_j < b_j \in \mathbb{R}$ , then  $\Theta^* = \prod_{j=1}^n [-\frac{1}{2(b_j-a_j)}, \frac{1}{2(b_j-a_j)}]$ . If  $\Theta$  does not have sides parallel to the coordinate axes, we claim without proof that there exists a rotation matrix  $R \in SO(n)$  so that  $R\Theta$  has sides parallel to the coordinate axes. Then define  $\Theta^* = R^{-1}(R\Theta)^*$ . We must (but won't) check that  $\Theta^*$  is independent of the choice of  $R$ . That these two definitions coincide is also worthy of proof but we will take this for granted here.

We note that when  $n = 1$  and  $\Theta = I$  is an interval, this coincides with our earlier definition of  $I^*$ . We also make the following observation.

**Lemma 2.** For all rectangles  $\Theta \subset \mathbb{R}^n$  and  $T \in SO(n)$ ,  $(T\Theta)^* = T(\Theta^*)$ .

*Proof.* Fix some  $R \in SO(n)$  such that  $\Theta^* = R^{-1}(R\Theta)^*$ . Then  $R(\Theta^*) = (R\Theta)^*$ . Since  $R\Theta = RT^{-1}(T\Theta)$  has sides parallel to the coordinate axes, we have

$$(T\Theta)^* = TR^{-1}(RT^{-1}(T\Theta))^* = TR^{-1}(R\Theta)^* = TR^{-1}R(\Theta^*) = T(\Theta^*).$$

□

**Proposition 2.** Given a rectangle  $\Theta \subset \mathbb{R}^n$  centred at  $\omega \in \mathbb{R}^n$ ,

$$\widehat{\mathbf{1}}_{\Theta}(\xi) = e^{-2\pi i \omega \cdot \xi} |\Theta| \mathbf{1}_{\Theta^*}(\xi).$$

*Proof.* First, assume that  $\Theta = \prod_{j=1}^n [a_j, b_j]$ , for some  $a_j < b_j \in \mathbb{R}$ . By Fubini's theorem, we have

$$\begin{aligned} \widehat{\mathbf{1}}_{\Theta}(\xi) &= \int_{\Theta} e^{-2\pi i x \cdot \xi} dx \\ &= \prod_{j=1}^n \int_{a_j}^{b_j} e^{-2\pi i x_j \xi_j} dx_j \\ &= \prod_{j=1}^n \widehat{\mathbf{1}}_{[a_j, b_j]}(\xi_j). \end{aligned}$$

From Proposition 1, we know that  $\widehat{\mathbf{1}}_{[a_j, b_j]}(\xi_j) = e^{-2\pi i \omega_j \xi_j} (b_j - a_j) \mathbf{1}_{[-\frac{1}{2(b_j-a_j)}, \frac{1}{2(b_j-a_j)}]}$ .

Since the cartesian product of the intervals  $[-\frac{1}{2(b_j-a_j)}, \frac{1}{2(b_j-a_j)}]$  is just  $\Theta^*$ , we have that  $\widehat{\mathbf{1}}_{\Theta}(\xi) = e^{-2\pi i \omega \cdot \xi} |\Theta| \mathbf{1}_{\Theta^*}(\xi)$ , as desired.

Now, for arbitrary  $\Theta$ , choose a rotation matrix  $R \in SO(n)$  as in the definition of  $\Theta^*$ , so that the edges of  $R\Theta$  are parallel to the coordinate axes in  $\mathbb{R}^n$ . Then  $\mathbf{1}_{\Theta}(x) = \mathbf{1}_{R\Theta}(Rx)$  and the centrepoint of  $R\Theta$  is  $R\omega$ . Applying Lemma 1(iii) and our argument above, we have

$$\widehat{\mathbf{1}}_{\Theta}(\xi) = \widehat{\mathbf{1}}_{R\Theta}(R\xi) = e^{-2\pi i R\omega \cdot R\xi} |R\Theta| \mathbf{1}_{(R\Theta)^*}(R\xi),$$

but since  $(R\Theta)^* = R(\Theta^*)$ ,  $|R\Theta| = |\Theta|$ , and  $R\omega \cdot R\xi = \omega \cdot \xi$ , this says exactly that  $\widehat{\mathbf{1}}_\Theta(\xi) = e^{-2\pi i\omega \cdot \xi} |\Theta| \mathbf{1}_{\Theta^*}(\xi)$ .  $\square$

As before, we notice that when  $\Theta$  is wide in a certain direction,  $\Theta^*$  is narrow in that same direction. As such, as for any  $y \in \Theta$ , the oscillations  $e^{-2\pi i\omega \cdot \xi}$  and  $e^{-2\pi iy \cdot \xi}$  cannot fall too far out of phase for  $\xi \in \Theta^*$ . Hence, we approximate  $\widehat{\mathbf{1}}_\Theta(\xi) \sim e^{-2\pi iy \cdot \xi} |\Theta| \mathbf{1}_{\Theta^*}(\xi)$  for any  $y \in \Theta$ .

**Tiling  $\mathbb{R}^n$  by Dual Rectangles.** Again, let  $\Theta \subset \mathbb{R}^n$  be a rectangle, and let  $\Theta^*$  be its dual rectangle. We can tile  $\mathbb{R}^n$  by translates of  $\Theta^*$ . Let  $\mathbf{T}_\Theta$  be the collection of  $\Theta^*$ -translates in this tiling. For the following proposition, we need to introduce

**Proposition 3.** Suppose  $f$  is a smooth function supported in  $\Theta$ . Then  $|\hat{f}|$  is constant on each tile  $T \in \mathbf{T}_\Theta$ .

*Proof.* First, assume  $\Theta$  is centred at 0, so that  $\widehat{\mathbf{1}}_\Theta = |\Theta| \mathbf{1}_{\Theta^*}$ . Since  $f$  is supported in  $\Theta$ , we have  $f = f \mathbf{1}_\Theta$ , and so

$$\hat{f} = \widehat{f \mathbf{1}_\Theta} = \hat{f} * \widehat{\mathbf{1}}_\Theta = \hat{f} * |\Theta| \mathbf{1}_{\Theta^*}.$$

We compute this convolution directly.

$$\hat{f} * |\Theta| \mathbf{1}_{\Theta^*}(\xi) = |\Theta| \int_{\mathbb{R}^n} \hat{f}(\eta) \mathbf{1}_{\Theta^*}(\xi - \eta) d\eta = \frac{1}{|\Theta^*|} \int_{\xi + \Theta^*} \hat{f}(\eta) d\eta.$$

The last equality holds because  $\Theta^*$  is centred at 0 and therefore symmetric, so  $\xi - \eta \in \Theta^*$  if and only if  $\eta \in \xi - \Theta^* = \xi + \Theta^*$ .

That is,  $\hat{f}(\xi)$  is the average of  $\hat{f}$  on  $\xi + \Theta^*$ . Now, as a second lie, we may approximate  $\xi + \Theta^*$  by the element  $T \in \mathbf{T}_\Theta$  containing  $\xi$ . If  $\xi \in T \in \mathbf{T}_\Theta$ , we therefore estimate that  $\hat{f}(\xi)$  is the average of  $f$  on  $T$ , which implies that  $\hat{f}$  is constant on  $T$ .

Now, suppose  $\Theta$  is centred at some arbitrary  $\omega \in \mathbb{R}^n$ . Define  $f_\omega(x) = f(x + \omega)$ , so that  $f_\omega$  is supported in  $\Theta - \omega$ , which is centred at 0. By Lemma 1, we have  $\hat{f}(\xi) = e^{-2\pi i\omega \cdot \xi} \widehat{f}_\omega(\xi)$  and so  $|\hat{f}| = |\widehat{f}_\omega|$ , which is constant on every  $T \in \mathbf{T}_\Theta$ , by the above argument.  $\square$

## SOBOLEV SPACES

We begin by presenting a first attempt at defining Sobolev spaces. Later, we will present a definition using Littlewood-Paley decompositions. Throughout this section, the symbol  $\alpha$  will denote a multi-index (an  $n$ -tuple  $(\alpha_1, \dots, \alpha_n)$  of natural numbers, including 0) and  $|\alpha| = \alpha_1 + \dots + \alpha_n$ . Given a function  $f \in C^{|\alpha|}(\mathbb{R}^n)$ , we write  $\partial^\alpha f = \frac{\partial^{|\alpha|} f}{\partial x_1^{\alpha_1} \dots \partial x_n^{\alpha_n}}$ .

Also, given a point  $x \in \mathbb{R}^n$ , we let  $x^\alpha = x_1^{\alpha_1} \dots x_n^{\alpha_n} \in \mathbb{R}$ . Also, we denote by  $\mathcal{S}(\mathbb{R}^n)$  the space of Schwartz functions on  $\mathbb{R}^n$ , and we denote by  $f^\vee$  the inverse Fourier transform of a function  $f$ .

**Definition 2.** Fix  $n \in \mathbb{N}$ . Given  $k \in \mathbb{N} \cup \{0\}$  and  $1 \leq p < \infty$ , we define for every  $f \in C_c^\infty(\mathbb{R}^n)$ ,

$$\|f\|_{W^{k,p}} = \left( \int_{\mathbb{R}^n} \sum_{|\alpha| \leq k} |\partial^\alpha f|^p dx \right)^{1/p}.$$

This defines a norm on  $C_c^\infty(\mathbb{R}^n)$ , and we let  $W^{k,p}(\mathbb{R}^n)$  be the completion of  $C_c^\infty(\mathbb{R}^n)$  with respect to this norm.

We note that this definition does not tell us how to realise  $W^{k,p}(\mathbb{R}^n)$  concretely. However, since  $\|f\|_{L^p} \leq \|f\|_{W^{k,p}}$  for all  $f \in C_c(G)$ , we infer that  $W^{k,p}(\mathbb{R}^n) \subset L^p(\mathbb{R}^n)$ , with a norm-decreasing inclusion.

**Theorem 1.** [Sobolev embedding theorem] If  $kp > n$ , then  $\|f\|_{L^\infty} \lesssim \|f\|_{W^{k,p}}$ . Therefore, we have a continuous inclusion  $W^{k,p}(\mathbb{R}^n) \subset L^\infty(\mathbb{R}^n)$ .

At first, this definition does not generalise easily to fractional orders  $k$ . However, for any  $f \in C_c^\infty(\mathbb{R}^n)$  and multi-index  $\alpha$ , we have by the Fourier inversion formula (and differentiating under the integral sign) that

$$\partial^\alpha f(x) = \int_{\mathbb{R}^n} (2\pi i \xi)^\alpha \hat{f}(\xi) e^{2\pi i x \cdot \xi} d\xi.$$

Therefore, for  $k \in [0, \infty) \setminus \mathbb{N}$ , we may be led to define

$$(1) \quad \|f\|_{W^{k,p}} := \left\| x \mapsto \int_{\mathbb{R}^n} |2\pi \xi|^k \hat{f}(\xi) e^{2\pi i x \cdot \xi} d\xi \right\|_{L^p} + \|f\|_{L^p}$$

and then define the Sobolev space  $W^{k,p}(\mathbb{R}^n)$  as the completion of  $C_c^\infty(\mathbb{R}^n)$  with respect to this norm. This completion will live inside  $L^p(\mathbb{R}^n)$ .

**Littlewood-Paley Decomposition.** Fix  $n \in \mathbb{N}$ . Given  $0 < r < R$ , let  $A(r, R)$  denote the annulus  $\{\xi \in \mathbb{R}^n : r < |\xi| < R\}$ . One may cover  $\mathbb{R}^n$  by a ball of radius 2 centred at the origin, and annuli  $A(2^{r-1} - \epsilon, 2^{r+1} + \epsilon)$ , for  $r \in \mathbb{N}$  and some small  $\epsilon > 0$ . We will construct a partition of unity subordinate to this cover.

Fix a smooth bump function  $\eta \in C_c^\infty(\mathbb{R}^n)$  such that  $\eta$  is radial,  $\eta(\xi) = 1$  when  $|\xi| \leq \frac{1}{2}$  and  $\eta(\xi) = 0$  when  $|\xi| \geq 1$ . We notice that for any  $\xi \in \mathbb{R}^n$ ,

$$1 = \eta(\xi) + \sum_{r=1}^{\infty} \left[ \eta\left(\frac{\xi}{2^r}\right) - \eta\left(\frac{\xi}{2^{r-1}}\right) \right],$$

since the right-hand side is a telescoping sum and  $\eta\left(\frac{\xi}{2^r}\right) = 1$  for sufficiently large  $r$ . (It also follows that this apparently infinite series is actually a finite sum.) Therefore, for each  $r \in \mathbb{N}$ , define

$$\eta_r(\xi) = \eta\left(\frac{\xi}{2^r}\right) - \eta\left(\frac{\xi}{2^{r-1}}\right).$$

We notice that when  $|\xi| \geq 2^r$  or  $|\xi| \leq 2^{r-2}$ , we have  $\eta_r(\xi) = 0$ . Therefore, each  $\eta_r$  is compactly supported inside the annulus  $A(2^{r-2} - \epsilon, 2^r + \epsilon)$ . For completeness, let's write  $\eta_0 = \eta$ . The collection of bump functions  $\{\eta_r\}_{r=0}^\infty$  is our desired partition of unity.

Now, fix  $f \in L^2(\mathbb{R}^n)$ . We wish to decompose  $f$  "on the Fourier side", using our partition of unity. Therefore, define functions  $P_r f \in L^2(\mathbb{R}^n)$  for  $r \geq 0$ , by the relation  $\widehat{P_r f}(\xi) = \eta_r(\xi)\hat{f}(\xi)$ .

We notice that  $\hat{f} = \sum_{r=0}^\infty \eta_r \hat{f}$  in  $L^2(\mathbb{R}^n)$ , by the dominated convergence theorem. Therefore, since the inverse Fourier transform is bounded on  $L^2(\mathbb{R}^n)$ , we have  $f = \sum_{r=0}^\infty P_r f$  in  $L^2(\mathbb{R}^n)$ . This is the **Littlewood-Paley decomposition** of  $f$ . We think of this as decomposing  $f$  based on its frequencies.

To define this decomposition for  $p \neq 2$ , we notice that  $P_r f = \eta_r^\vee * f$ . Since  $\eta_r \in C_c^\infty(\mathbb{R}^n) \subset \mathcal{S}(\mathbb{R}^n)$ , we have  $\eta_r^\vee \in \mathcal{S}(\mathbb{R}^n) \subset L^1(\mathbb{R}^n)$ . By Young's convolution inequality, convolution by a fixed  $L^1$  function determines a bounded operator on  $L^p(\mathbb{R}^n)$  for every  $1 \leq p \leq \infty$ . Therefore, for any  $f \in L^p(\mathbb{R}^n)$ , we may define  $P_r f = \eta_r^\vee * f \in L^p(\mathbb{R}^n)$ .

By the following theorem, this definition gives us an equivalent characterisation of the Sobolev space  $W^{k,p}(\mathbb{R}^n)$ .

**Theorem 2.** Fix  $k \geq 0$  and  $1 < p < \infty$ . For any  $f \in W^{k,p}$ , we have

$$(2) \quad \|f\|_{W^{k,p}} \approx_{\alpha,p,n} \left\| \left( \sum_{r=0}^\infty |2^{rk} P_r f|^2 \right)^{1/2} \right\|_{L^p}.$$

We emphasise that these norms are not equivalent at the endpoints  $p = 1$  and  $p = \infty$ . We will not provide a proof of this theorem, but we can present two heuristics for its plausibility.

First, notice that  $\widehat{\partial^\alpha P_r f}(\xi) = (2\pi i \xi)^\alpha \widehat{P_r f}(\xi) = (2\pi i \xi)^\alpha \eta_r(\xi) \hat{f}(\xi)$ . For  $r \geq 1$ , since  $\eta_r(\xi)$  is supported where  $2^{r-2} \leq |\xi| \leq 2^r$ , we have for a large region in  $\mathbb{R}_\xi^n$ ,

$$|(2\pi i \xi)^\alpha \eta_r(\xi) \hat{f}(\xi)| \approx 2^{r|\alpha|} |\eta_r(\xi) \hat{f}(\xi)| = 2^{r|\alpha|} |\widehat{P_r f}|.$$

(Of course, this estimate fails when, say,  $\alpha$  picks up only the first coordinate and  $\xi_1 = 0$ .)

As a second piece of intuition, we notice that, inside the  $L^p$ -norm on the right-hand side of (2), we have what looks like an  $\ell^2$ -norm of terms  $2^{r\alpha} P_r f$ . We note that since  $f = \sum_{r=0}^{\infty} P_r f$ , we have  $|f| \leq \sum_{r=0}^{\infty} |P_r f|$  by the triangle inequality. This is an estimate on  $f$  by an  $\ell^1$ -norm. Moreover, if  $\{a_r\}_{r=1}^{\infty}$  is a sequence of numbers, then  $\|(a_r)\|_{\ell^2} \leq \|(a_r)\|_{\ell^1}$ . Thus, to say that  $\ell^2$ -norm in Theorem 2 is equivalent to  $\|f\|_{W^{k,p}}$  is a way of saying that there is some square-root cancellation between the different Littlewood-Paley pieces.

If we think of the maps  $f \mapsto P_r f$  as Fourier projections onto disjoint annuli of radius approximately  $r$ , then we obtain the equations  $P_r(P_r f) = P_r f$  and  $P_s(P_r f) = 0$  when  $r \neq s$ . If we accept this heuristic, then the following estimate falls out immediately from Theorem 2. Of course, the heuristic is not quite true, but with some technical work, one can still deduce this corollary.

**Corollary 1.**  $\|P_r f\|_{W^{k,p}} \approx 2^{rk} \|P_r f\|_{L^p}$ .